

Pipetman®

Care and Maintenance

**Complete Guide to Troubleshooting and Repairing
Pipetman Models P-2 through P-10ML and P-200-M8**

Contents

Subject	Page
INTRODUCTION	2
TROUBLESHOOTING	3
PIPETMAN GUIDELINES	4
SEALING SYSTEM	5
Disassembly	
Shafts	
Pistons	
Seals	
FRICTION RING	6
PLUNGER	7
MICROMETER	8
TIP EJECTOR	9
MODEL P-200-M8 LIQUID END	10
REPLACEMENT PARTS	11
SCHEMATICS	12-16

Introduction

Pipetman pipettes are designed to provide years of exceptional performance and reliability. Yet when subjected to physical or chemical hazards, parts can be damaged, impairing pipette integrity and usefulness.

This guide is intended to help you identify typical Pipetman problems and take proper corrective action. Most repairs can be completed in your lab in a few minutes. In some cases, repairs will require professional service and recalibration. Rainin is the only factory-authorized provider of repair and recalibration services for Pipetman. We are committed to helping you extend the life and maintain reliability of your Pipetman instruments.

Replacement Part Orders: 800-472-4646

Technical Service: 800-543-4030

Pipette Service: 800-662-7027

Rainin Service Centers:	Rainin Road Woburn MA 01801	7500 Edgewater Dr Oakland CA 94621	5955 Mira Mesa Blvd, Ste B, San Diego CA 92121
--------------------------------	-----------------------------------	--	--

Pipetman Identification

Throughout this guide you will find references to various Pipetman styles and parts. Identify your Pipetman according to this list:

- | | |
|-------------------------------------|---|
| Original Pipetman: | Introduced in 1971. Body is clear plastic, machined, not molded. |
| Blue-Body Pipetman: | Introduced in June 1975. Molded blue plastic body. No serial number. |
| Old-Style Pipetman: | Introduced in July 1979. Serial numbers range from H-79xxxx through N-85xxxx. Two-piece piston assemblies introduced June 1982 (G-82xxxx). |
| New-Style Pipetman: | Introduced in January 1986 featuring a sturdier 6-hole calibration mechanism and new serial numbers CxxxxxA through JxxxxxA. |
| Modified Pipetman: | Introduced in February 1991 featuring a new long-life friction ring. Serial numbers are JxxxxxB through NxxxxxE. Schematics appear on page 12–16. |
| Plunger-Adjustable Pipetman: | Introduced in December 1995 featuring easier adjustment by using the volume adjustment knob or by turning the plunger button. Serial numbers range from NxxxxxE and higher. |

Troubleshooting

Use this checklist when you have a problem with Pipetman. Refer to the page indicated for corrective action.

SYMPTOM	POSSIBLE CAUSES	SEE PAGE
Pipette is leaking sample or won't aspirate sample	Tip ejector is interfering with tip seal	9
	Seal worn prematurely due to piston corrosion	5
	Piston damaged or corroded	5
	Seal worn after extensive use	5
	Shaft damaged or worn	5
	Pipette improperly reassembled	8-9
	Pipette improperly repaired	5-10
Pipette is inaccurate	Micrometer overwound	8
	Pipette improperly repaired	5-10
Measurements not reproducible or poor precision	Pipette improperly calibrated/evaluated	AB-15
	Incorrect operator technique	4
	Tip ejector interfering with tip seal	9
	Seal worn prematurely due to piston corrosion	5
	Piston damaged or corroded	5
	Seal worn after extensive use	5
	Shaft damaged or worn	5
Friction ring missing or cracked	Normal wear and tear	6
Volume setting changes Tips fall off/won't fit	Friction ring is worn or missing during operation	6
	Tip ejector is slipping	9
	Shaft end is damaged or worn	5
	Not using Rainin tips	4
Plunger sticks/scraping	Plunger bent	7
	Plunger damaged from corrosives	7
Micrometer digits misaligned	Micrometer parts worn	8
P-200-M8: Nozzle leaking, won't aspirate	Nozzle damaged or worn	10
	Piston needs lubrication	10
	Worn piston seal	10
	Improperly reassembled	10
	Improperly repaired	10
Ejector rake won't return to "up"	Return to Pipette Service Department	10

For detailed information on evaluating pipette performance, request Rainin publication AB-15, Procedure for Evaluating Accuracy and Precision of Rainin Pipettes.

Guidelines

Review these guidelines before you begin repairs. Many symptoms can be resolved through better understanding of the Pipetman air-displacement system and pipetting techniques.

1. To properly set Pipetman volume, turn the volume adjustment knob until you are 1/3 revolution above the desired volume setting. Then return clockwise to the desired volume. This will eliminate mechanical backlash.
2. When picking up a sample, immerse the end of the disposable tip beneath the liquid surface within the following ranges:
 - 1 to 2 mm - up to 10 μL
 - 2 to 3 mm - 10 to 100 μL
 - 3 to 6 mm - 100 to 1000 μL
 - 6 to 10 mm - 5000 μL or more
3. Prerinse tips whenever critical reproducibility is required.
4. Maintain consistency in the following areas:
 - pipetting rhythm from sample to sample.
 - speed and smoothness when you press and release the push button.
 - push button pressure at the first stop.
 - angle and immersion depth.
5. Always operate Pipetman in a vertical position.
6. Dispense sample by touching the tip end against the side wall of the receiving vessel to ensure complete sample flow.

Limitations

Pipetman performance within published specifications is guaranteed by Rainin only when using Rainin tips.

Pipetman pipettes will produce accurate and precise measurements of liquids with density, viscosity and vapor pressure similar to water. For other liquids, use a positive-displacement pipettes.

Sealing System

Disassemble the liquid end first to avoid damage and lost parts.

1. Remove the tip ejector arm by pulling downward.
Use pliers if necessary.
2. CAUTION: Unscrew the shaft coupling **slowly** while holding the body and shaft firmly. Note that the internal piston assembly is spring loaded and will release when the shaft coupling is disengaged. Be extra careful when disassembling the P-2 and P-10; the parts are extremely small and fragile.
3. Remove Piston Assembly from the shaft. If the seal remains in the shaft, tap the shaft on a tabletop to loosen. If necessary, carefully prod with a cotton swab.

Shaft: Inspect the tip sealing end of the shaft for scratches, wear marks and splits. Hint: To expose splits, insert the small end of a disposable tip into the shaft end. Also note general cleanliness and inspect for obstructions inside the shaft.

Salvageable shafts should be cleaned inside and out with isopropyl alcohol and cotton swabs or Kimwipes. Damaged shafts should be replaced. Calibration will not be effected by shaft replacement. Hint: Tip sealing can be improved by lightly wiping the shaft end with acetone and a paper towel. Do not do this on P-10ML shafts.

Piston: Expose the piston surface. If the stainless steel surface is highly polished, the piston remains in original condition and has not been damaged. If the piston is lightly stained or dirty, clean with isopropyl alcohol and non-abrasive cloth. Be sure parts are dry before reassembly. If the surface is scratched, heavily stained, corroded, lubricated or bent, the piston is in need of professional repair or replacement. Return to Rainin for service or replace the piston and recalibrate in accordance with instructions described in Rainin publications 9920-209 and AB-15.

NOTE: A calibration tool is required for recalibrating the pipette.

Polyethylene Seal: Slide the polyethylene seal up and down on the piston. If the seal has resistance throughout the full length of the piston, it remains in good condition. If the resistance is spotty or non-existent, replace the seal. Calibration will not be effected by seal replacement.
DO NOT REPLACE OR LUBRICATE THE SEAL IF THE PISTON IS DAMAGED.

O-Ring: Extremely durable and not subject to wear. Does not usually require replacement.

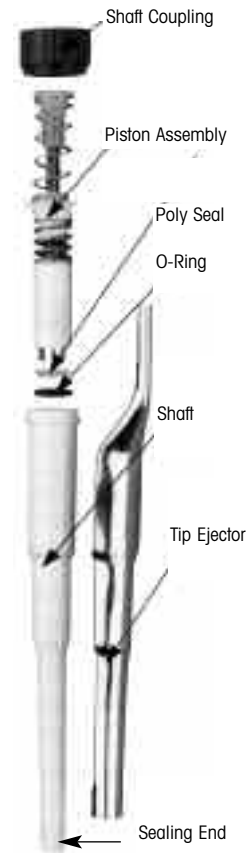

The original P-10ML seal (pre s/n N05803D) is formed by an O-ring with fluorinated grease. Remove the old O-ring and clean all traces of grease from piston. Smear a light coat of fresh grease on the new O-ring and piston. Reassemble.

Friction Ring

Evaluation

Inspect the friction ring for splits or cracks. If the ring is damaged or no longer present, replacement is necessary. To prepare, turn the volume adjustment knob so the friction ring is easily accessible. Using a sharp scalpel or razor blade, carefully cut the friction ring and remove all pieces.

Replacement for Blue-Body and Old-Style Pipetman:

1. Remove the plunger button by pulling straight off.
2. Using a 2 mm Allen wrench, loosen the three silver set screws at the bottom of the volume adjustment knob and remove the knob.
3. Mount the new friction ring (P/N 400114). You may need to adjust the ring to assure proper seating.
4. Reseat the volume adjustment knob flush with the top of the microbolt.
5. Retighten the silver set screws evenly and replace the plunger button.

Replacement for New-Style Pipetman (CxxxxxA - JxxxxxA Series):

1. Rotate the volume adjustment knob counter-clockwise until the microbolt assembly can be removed. Once removed, view the white tab (key) inside the Pipetman body. This tab allows manual manipulation of the digital display.
2. Mount the new friction ring (P/N 400114). The ring may need to be adjusted to assure proper seating.
3. If necessary, reset the digital display as indicated in **V1** by using extended forceps to manipulate the white tab.
4. Reinsert the microbolt assembly into the Pipetman body without rotation of the volume display. Note: The tab inside the body must align with the groove on the microbolt. Then screw the volume adjustment knob past zero until it will rotate no further. The volumeter display should correspond with **V2** below.

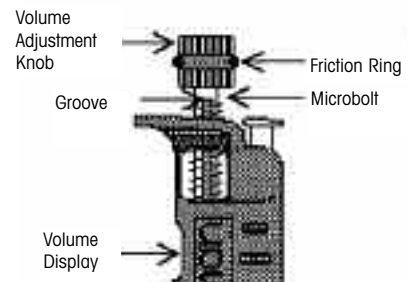

Model	V1	V2
P-10, P-100, P-1000, P-10ML	130-133	996 ±3
P-2, P20, P-200	310-315	980 ±5
P5000	630-675	970 ±5

Modified and Plunger-Adjustable Pipetman (JxxxxxB series or higher):

Friction rings on these pipettes are designed for significantly longer life. They cannot be replaced in the field. Call Rainin Technical Assistance at 800-543-4030 for advice.

Plunger

Evaluation

Three styles of plungers exist: those that are permanently attached to the piston assembly (pre G-82xxxx one-piece assembly); those that are metal and separate from the piston assembly (G-82xxxx to NxxxxE two-piece assembly); and those that are metal and separate, with a star-shaped internal plastic rod for the Plunger-Adjustable Pipetman (NxxxxE and higher).

If a plunger binds at any point in normal operation, repair or replacement is necessary.

Plunger Repair (all styles except Plunger-Adjustable)

1. Set pipette to its nominal setting.
2. Stroke plunger and observe for the binding point on plunger.
3. With your thumbs on the plunger button, press opposite the bend.
4. Repeat steps 2 and 3 until smooth action is achieved. If smooth action cannot be achieved, the plunger must be replaced. For one-piece piston assemblies, the entire piston and plunger assemblies require replacement. Recalibration is required after piston change.

Two-Piece Plunger Replacement (all styles except Plunger-Adjustable)

1. Remove the tip ejector by pulling downward on the metal arm.
2. Remove plunger button by pulling straight off.
3. Carefully unscrew the shaft coupling while holding the shaft and pipette body firmly. Note that the internal piston assembly is spring loaded and will release when the shaft coupling is disengaged. Be extra careful when disassembling models P-2 and P-10. They have small parts that can be easily lost.
4. Carefully remove the piston assembly with the shaft. The plunger should now fall freely through the Pipetman body. If severely bent, carefully push through.
5. Replace the plunger (P/N 23861) and reassemble the pipette. Calibration may be effected. Use the gravimetric method described in AB-15 to verify calibration.

Plunger-Adjustable Plunger Replacement

1. Remove the plunger button by pulling straight off.
2. Set the micrometer to zero.
3. Using the calibration tool (P/N CT-1) turn the calibration adjustment screw counter-clockwise until the adjustment screw has been removed from the volume adjustment knob.
5. Install the new plunger (P/N 44761) ensuring the rod is fully seated in the microbolt.
6. Reinstall the calibration adjustment screw, turning clockwise until the screw is installed in the volume adjustment knob at the approximate position prior to removal.
7. Align the hexagonal hole of the plunger button with the hexagonal section of the plunger. Push the button firmly onto the plunger until definite seating is noted. If the plunger button is loose or seems to be unsteady, the button must be replaced. Refer to the parts list on page 11 for the proper replacement part number.
8. Recalibrate the pipette in accordance with instructions found in 9920-209 and AB-15.
NOTE: A calibration tool is required for recalibrating the pipette

Micrometer

Evaluation

Observe the 3-digit volume indicator for proper sequence while turning the volume adjustment knob. If not sequential, see Micrometer Out-Of-Phase instructions below. For New Style, Modified, and Plunger-Adjustable Pipetman (CxxxxxA and higher), confirm proper zero-set of microbolt. Wind the volume adjustment knob clockwise until no further travel of the microbolt assembly is allowed. View the digital display and compare to **V1** in the table below. If the display value exceeds the **V1** range, the micrometer has been overwound.

Micrometer Out-Of-Phase (All styles):

When numbers are misaligned or non-functional, the micrometer is out-of-phase. It cannot be repaired in field. Return to Rainin for repair.

Overwound Micrometer Repair for New Style, Modified, and Plunger-Adjustable Pipetman (CxxxxxA and higher):

1. Rotate the volume adjustment knob counter-clockwise until the microbolt assembly can be removed. Once removed, view the white tab (key) inside the Pipetman body. This tab allows manual manipulation of the digital display.
2. By using extended forceps, reset the digital display as indicated in **V2** by manipulating the white tab.
3. Reinsert the microbolt assembly into the Pipetman body without moving the digital display. Align the groove in the microbolt with the white tab. While applying downward pressure, wind the volume adjustment knob clockwise until no further travel of the microbolt assembly is allowed.
4. View the digital display and compare to **V1**. If the display value exceeds the range, the micrometer is still not properly zero-set. Try again.

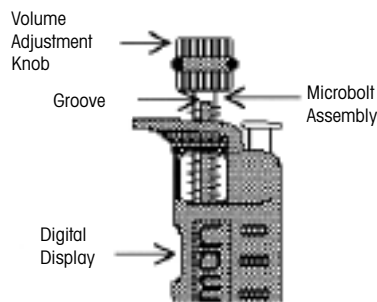

Model	V1	V2
P-10, P-100, P-1000, P-10ML	996 ±3	130-133
P-2, P-20, P-200	980 ±5	310-315
P-5000	970 ±5	630-675
Plunger-Adjustable Pipetman:		
P-10, P-100, P-1000	995 ±1	135 ±3
P-2, P-20, P-200	980 ±5	325 ±5
P-5000	970 ±10	670 ±10

Tip Ejector

Evaluation

If the tip ejector arm binds during normal operation, it usually means the ejector arm is bent and should be replaced. If the tip ejector mechanism has sprung apart, return the instrument to Rainin for repair. If the ejector arm interferes with proper positioning of Rainin tips on the shaft, the ejector has slipped from its original position. Reposition it by following the procedure described below.

1. Remove the tip ejector arm. Use pliers if necessary.
2. Slightly crimp the post end of the tip ejector arm.
3. Reposition the tip ejector arm and confirm tip clearance.

NOTE: Not applicable to series NxxxxxE or higher with non-slippage blue collar adapter.

REMOVING THE TIP EJECTOR ARM

Press the tip ejector button and pull the tip ejector arm out from the instrument handle.



REPLACING THE TIP EJECTOR ARM

Hold the instrument upside down with the tip ejector button pressed against a table edge and the plunger hanging over the edge. Place the upper end of the ejector arm onto the post inside the instrument handle and press. Make sure the ejector arm is pushed into the handle so the tips will fit properly on



P-200-M8 Liquid end

Disassembly

1. Set the volume to zero.
2. Using a 1/16 inch Allen (hex) wrench, remove the two screws from the back and the four screws from the front of the liquid end. (Older models will require a small Phillips screwdriver.)
3. Lift off the tip ejector assembly.
4. Locate the nozzle/piston assembly in question and remove by pulling straight up. Examine the plastic nozzle for scratches, wear, and cracks. Worn nozzles may be reconditioned to improve the seal between the nozzle end and tip.
5. Apply acetone to a paper towel. Insert the bottom end of the nozzle into the paper towel and twist several times. Some dulling of the nozzle finish may occur. This is usually only a temporary situation. If a nozzle cannot be salvaged, replace the nozzle/piston assembly.
6. Examine the piston surface. The piston should have a highly polished stainless steel finish.
7. Clean the piston with isopropyl alcohol using a non-abrasive cloth. Reapply a light coating of silicone grease (P/N 1600-038) and slide piston into the nozzle.
8. If the piston is scratched, stained, or corroded, and regreasing does not solve the problem, replace the nozzle/piston assembly (P/N 6102-259, pkg of 2; 6102-260, pkg of 8).

NOTE: Nozzles may be purchased separately if pistons are in good condition.
(P/N 6102-266, pkg of 8, includes grease)

Nozzle Replacement

1. Position the nozzle/piston assembly directly above the vacant slot.
2. Push the piston clip into the piston bar slot.
3. Align the locating tab on the nozzle/piston assembly and firmly engage it in the locating slot in the box assembly. This should be a snug fit. All nozzles should line up evenly.
4. Replace the tip ejector assembly. Make certain it is flush and all nozzles are secure and in line.
5. Replace the six screws. Do not overtighten.

Nozzle/piston assemblies are replaced concurrently to ensure the P-200-M8 performs to specifications.

Replacement Parts

DESCRIPTION	P-2 F-1MIC- F-2MIC	P-10 F-2.1MIC- F-10MIC	P-20 F-1 - F-20	P-100 F-21- F-100	P-200 F-101- F-200	P-1000 F-201- F-1000	P-5000 F-1001- F-5000	N05803D P-10ML F-5001- F-10ML	N05806D P-10ML F-5001- F-10ML
SEAL (POLYETHYLENE)	44815	44818	23359	44604	23350	23374	23118	NA	61828
O-RING	400071	400071	400013	400067	400001	400003	400006	6192-015	* 400025
SHAFT **	44816	44819	23353	44602	23305	23371	23608	6192-016	61263
SHAFT COUPLING	23654	23654	23654	23654	23654	23654	NA	NA	NA
FRICTION RING	400114	400114	400114	400114	400114	400114	400114	400114	NA
ALL PRE-1991 MODELS, PRE-JXXXXX SERIES (RUBBER ONLY)									
TIP EJECTOR ARM **	44829	44829	23657	44605	23658	23659	NA	NA	NA
PLUNGER	23861	23861	23861	23861	23861	23861	23861	23861	NA
ALL PRE-1996 MODELS, PRE-NXXXXX SERIES									
PLUNGER-ADJUSTABLE MODELS, NXXXXX AND HIGHER	44761	44761	44761	44761	44761	44761	44761	NA	44761
PLUNGER BUTTON	44823	44824	23660	44607	23661	23662	23663	61223	61223
PRE-NXXXXX SERIES									
PLUNGER-ADJ. NXXXXX AND HIGHER	844781	844782	844783	844784	844785	844786	844787	861281	861281
SEAL ASSEMBLY HOLDER	44817	44817	23354	44603	23306	NA	NA	NA	NA
SPRING, SMALL	300066	300066	300047	300047	300047	NA	NA	NA	NA
SPRING, LARGE	300042	300042	300042	300004	300004	NA	NA	NA	NA
SPRING POSITIONER									
SMALL	23871	23871	23871	23871	23871	NA	NA	NA	NA
LARGE	44214	44214	44214	44214	44214	NA	NA	NA	NA
CALIBRATION TOOL	CT-1 FOR MODELS CXXXXX AND HIGHER PRE-APPROVAL REQUIRED. CALL TECHNICAL SUPPORT AT 800-543-4030.								
FILTER	NA	NA	NA	NA	NA	NA	6190-164	6190-164	6190-164
100/BOX	NA	NA	NA	NA	NA	NA	6190-165	6190-165	6190-165
1000/BOX									
PISTON ASSEMBLY	REPLACEMENT FOR MODELS P-2 THRU P-10ML REQUIRE RECALIBRATION. CALL TECHNICAL SUPPORT-800-543-4030.								

* INCLUDES GREASE

** AUTOCLAVABLE

† REPLACEMENT FOR ALL MODELS REQUIRES RECALIBRATION. CALL TECHNICAL SUPPORT AT 800-543-4030.

P200-M8 Multichannel Pipette

EJECTOR ASSEMBLY	PLUNGER BUTTON ††	PLUNGER BUTTON †	SILICONE GREASE	PISTON ASSEMBLY		
				REPLACEMENT NOZZLES 8/PKG	PISTONS/ NOZZLES 2/PKG	PISTONS/ NOZZLES 8/PKG
6102-214	23661	861081	1600-038	6102-266	6102-259	6102-260
				INCLUDES GREASE		

†† PRE-NXXXXX SERIES

† PLUNGER-ADJ. NXXXXX AND HIGHER

Schematics

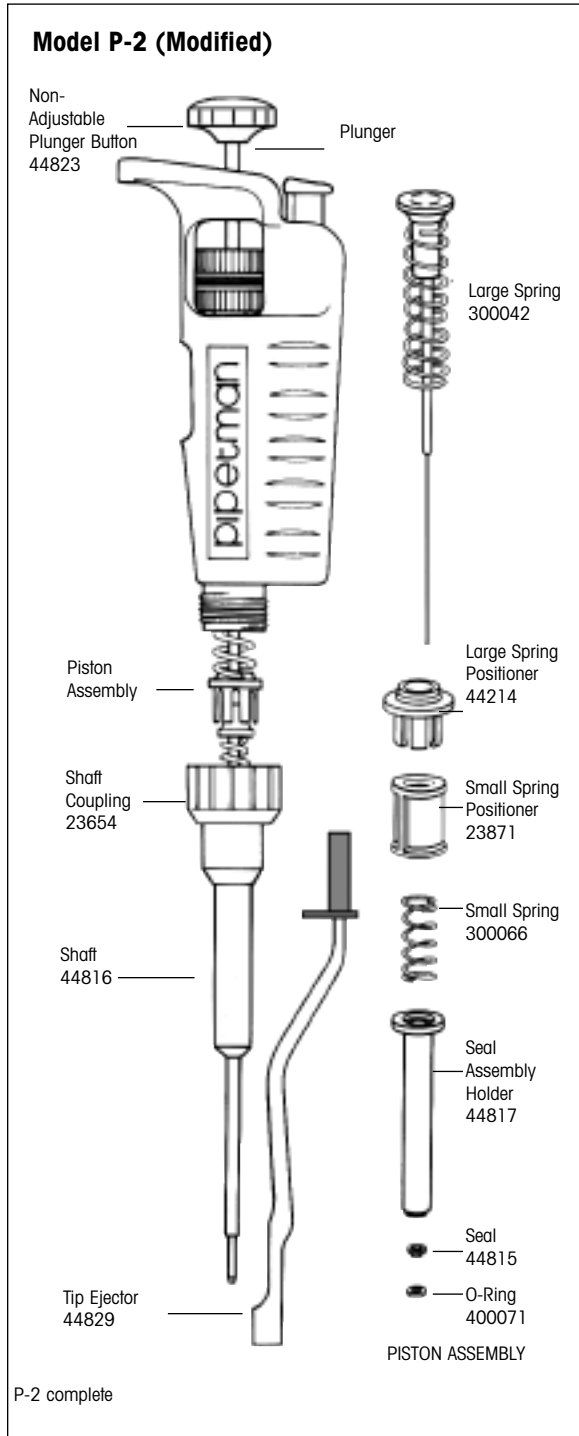

Adjustable Plunger
Button: 844781
Plunger: 44761

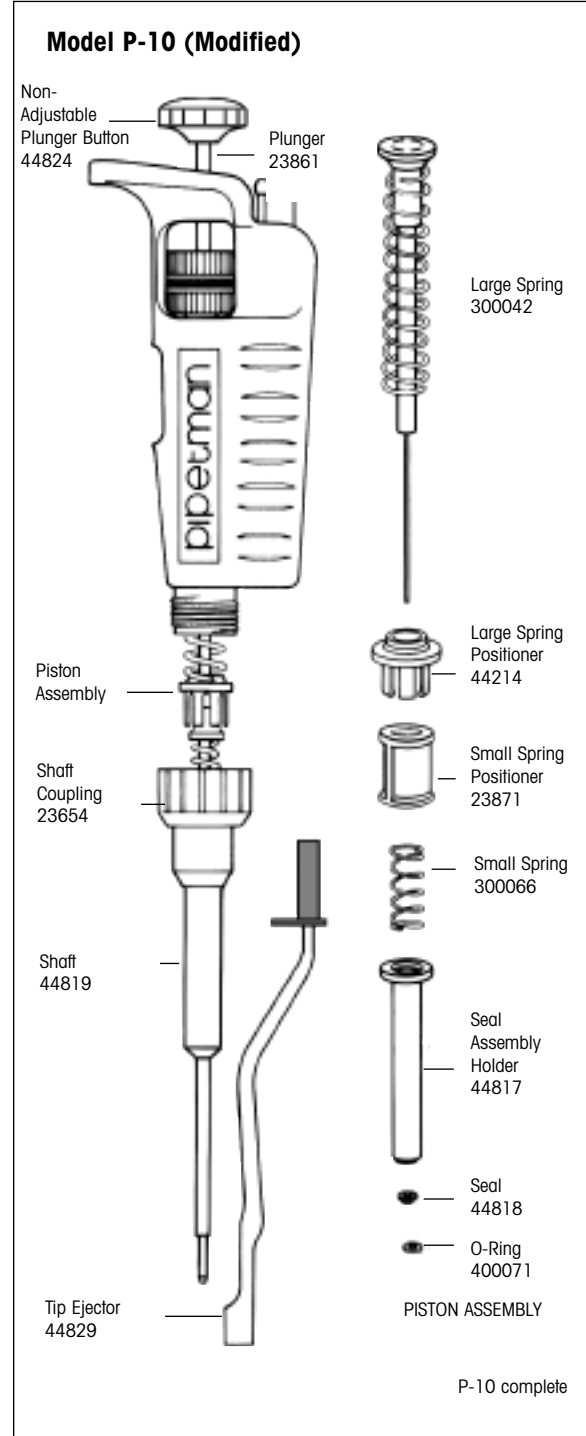

Adjustable Plunger
Button: 844782
Plunger: 44761

Schematics

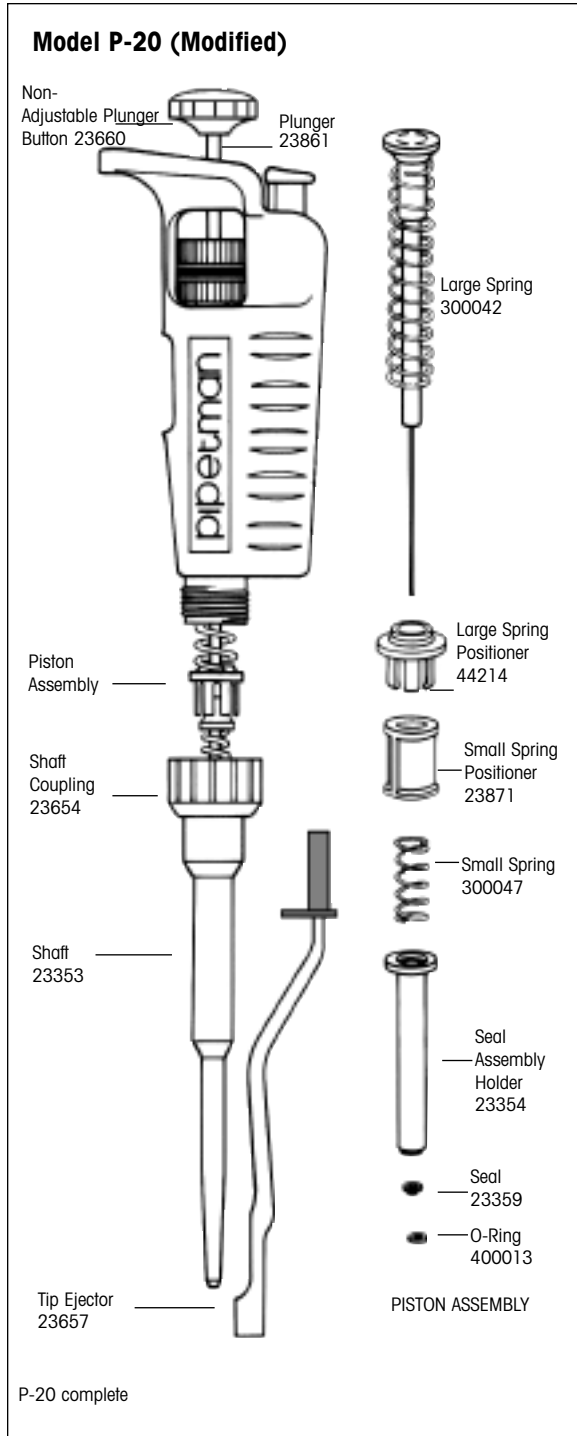

Adjustable Plunger Button: 844783
Plunger: 44761

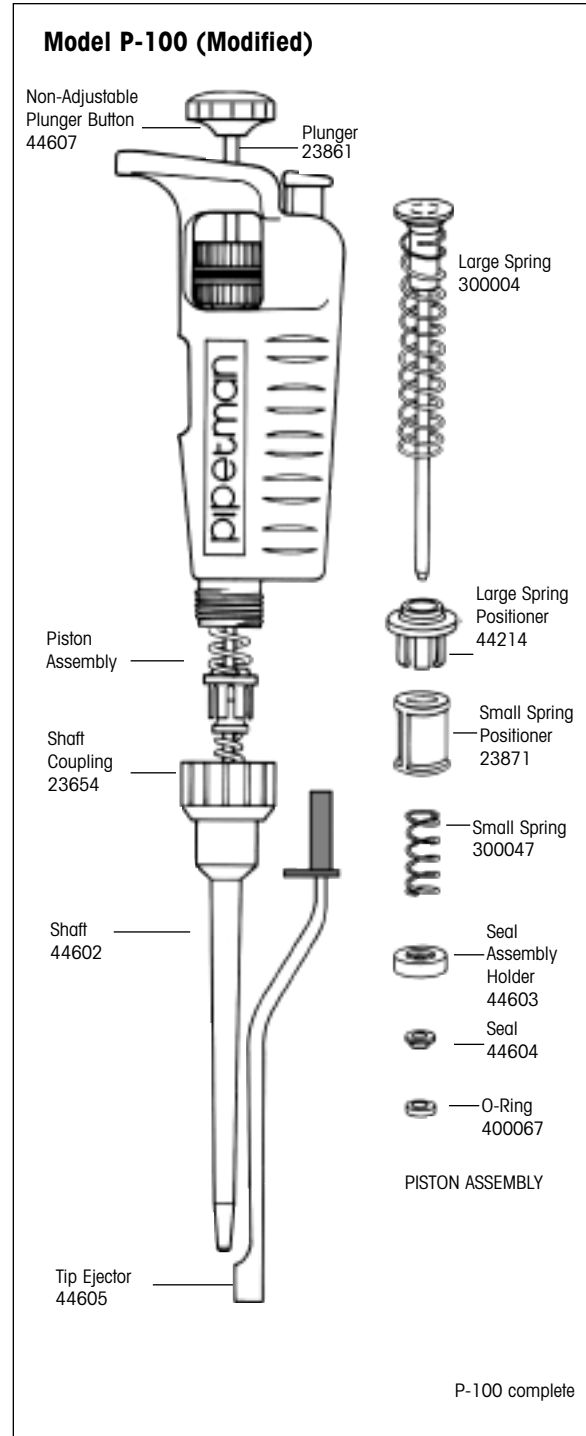

Adjustable Plunger Button: 844784
Plunger: 44761

Schematics

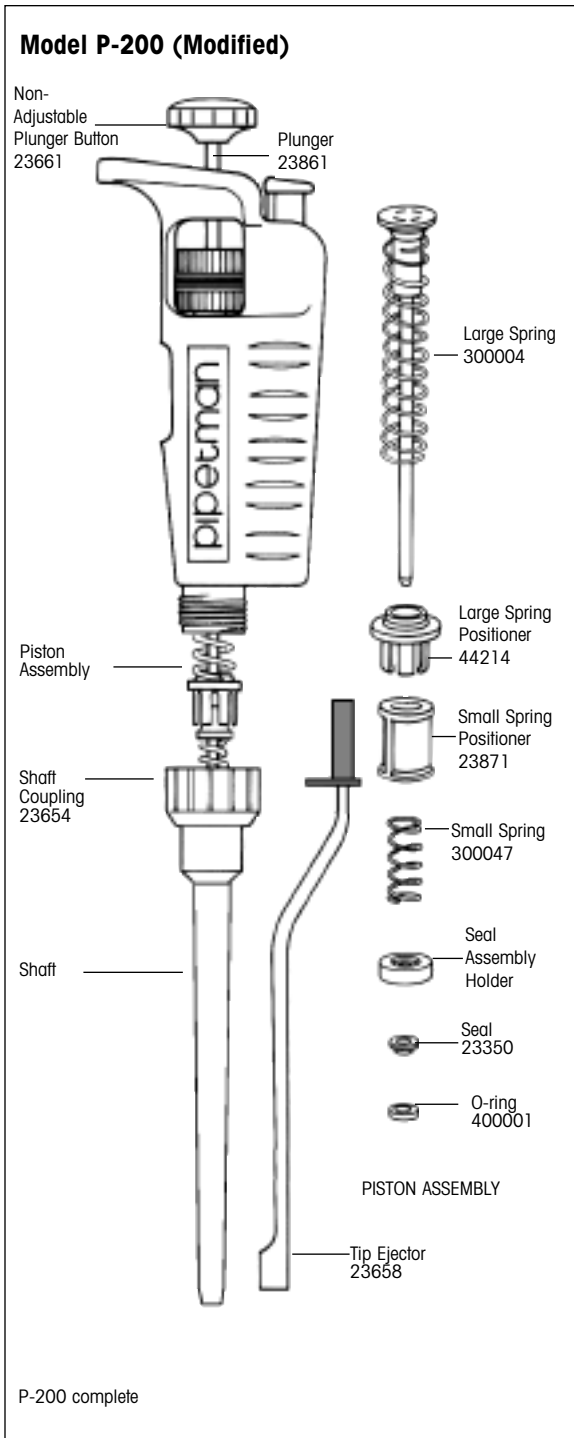

Adjustable Plunger Button:
844786
Plunger: 44761

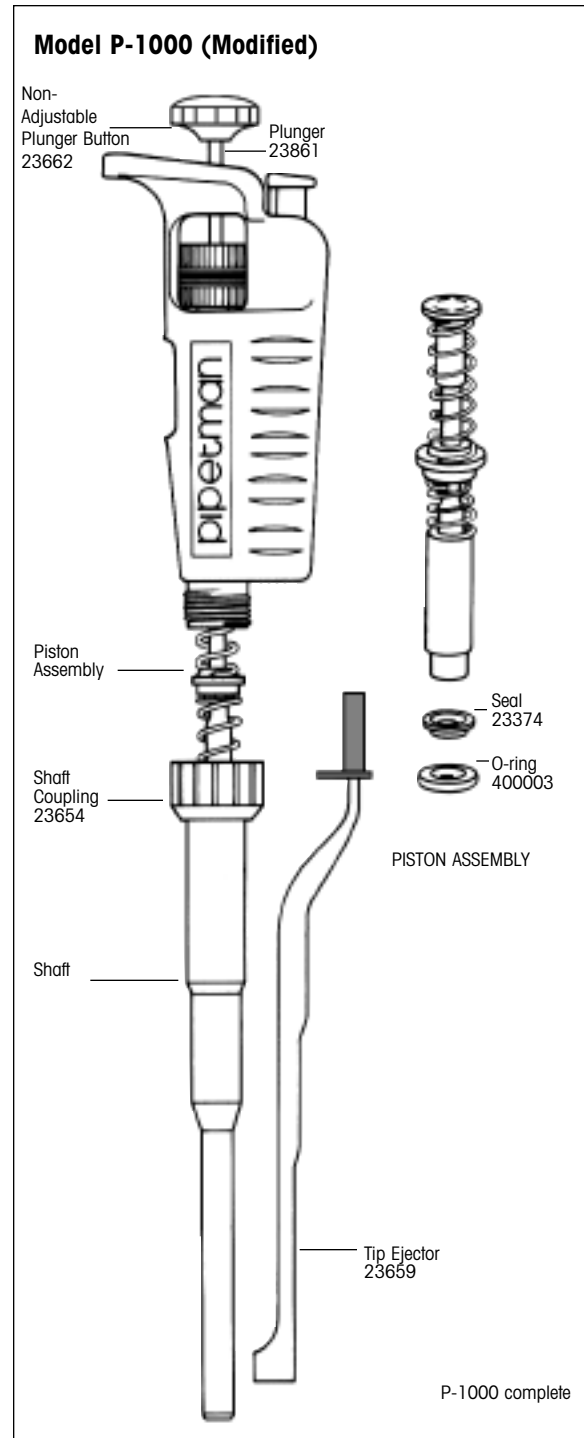

Adjustable Plunger Button: 844786
Plunger: 44761

Schematics

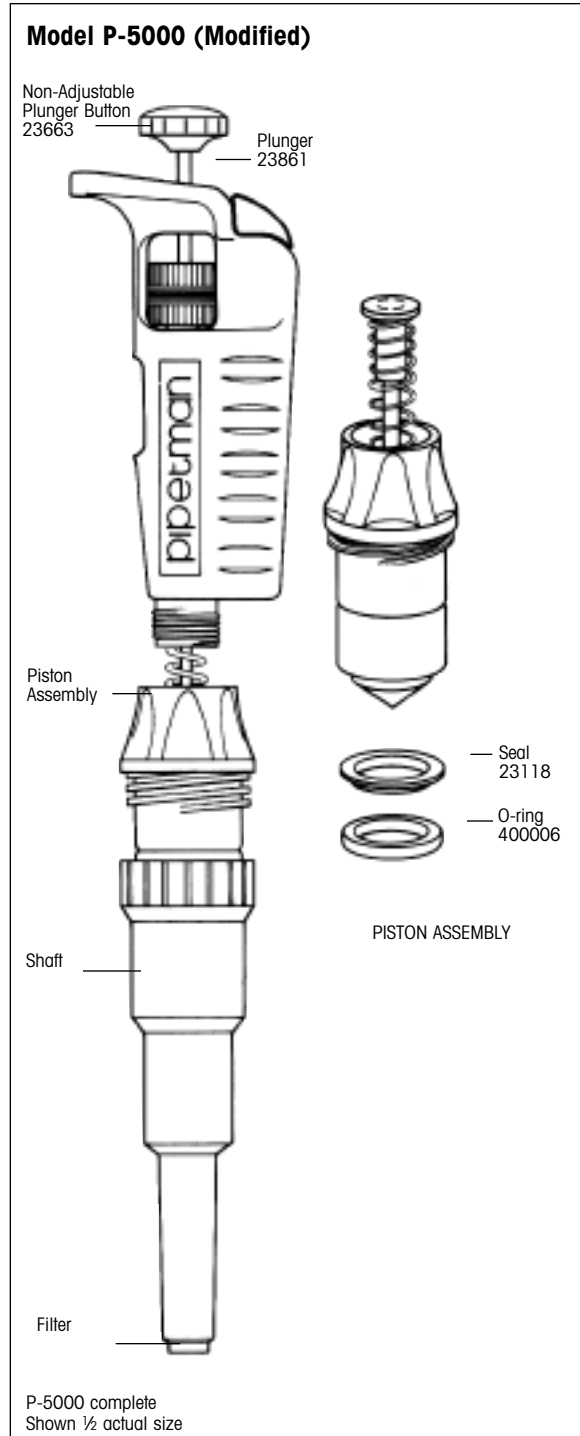

Adjustable Plunger Button: 844787
Plunger: 44761

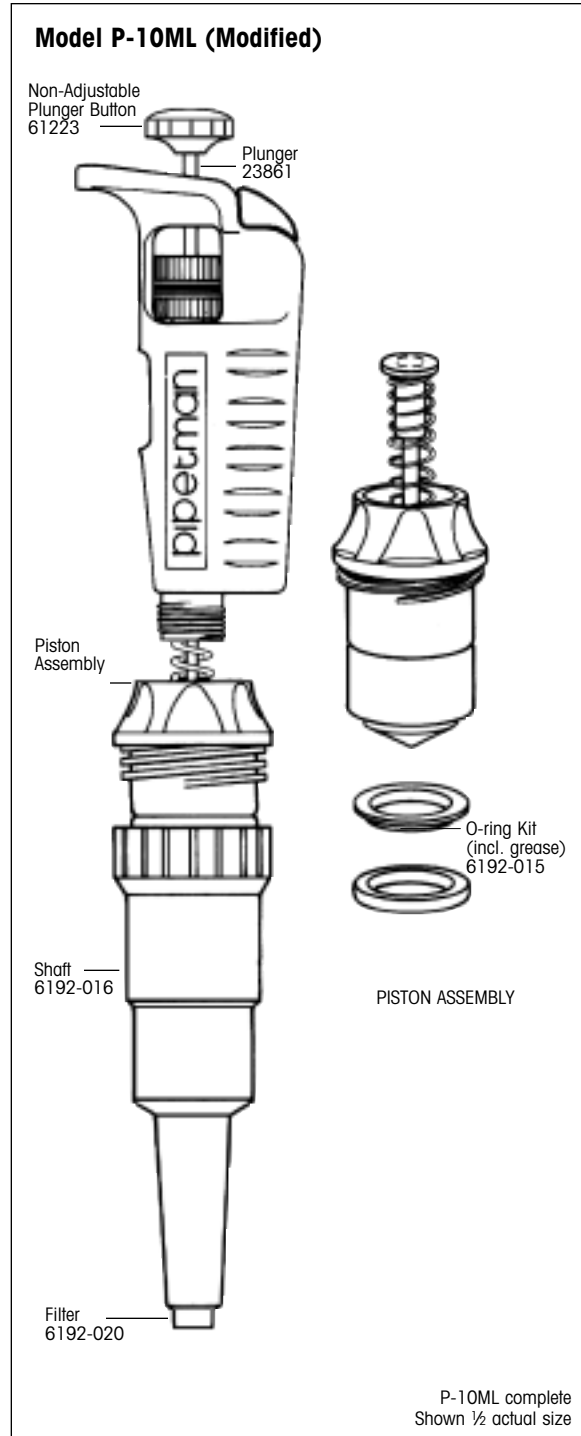

Adjustable Plunger Button: 861281
Plunger: 44761

Schematics

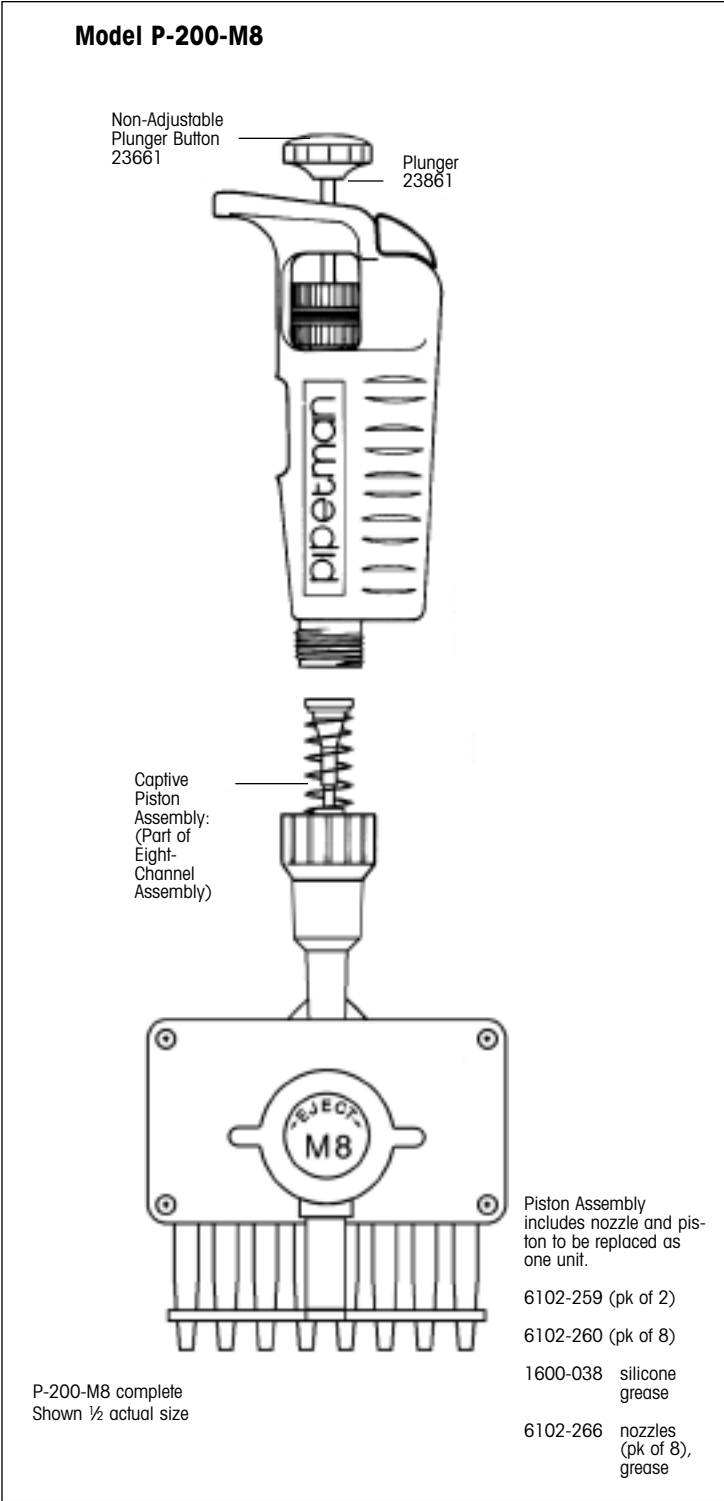

Adjustable Plunger Button:
861081
Plunger: 44761

Rainin Instrument, LLC
7500 Edgewater Drive, Box 2160 Oakland, CA 94621-0060
510-564-1600 • 800-472-4646 (800 4 RAININ)

Web:	www.rainin.com
Customer Service	pipets@rainin.com
Technical Service	tech.service@rainin.com
Pipette Service	service@rainin.com